

2" WG
Pos. or Neg. **Rectangular Duct Standards**
S & Drive Construction



Fabricated in accordance with the 1995 SMACNA HVAC Duct Construction Standards

	Duct Dimension	Joint Connection	Max. Length	Metal Gauge	Reinforcing Size and Longitudinal Spacing
Width	0" - 10"	T-6 Hemmed "S" Slip	59"	26	Transverse Connection 59" O.C.
Depth	0" - 30"	T-1 Drive Slip			
Width	11" - 14"	T-11 Standing "S" Slip	59"	26	Transverse Connection 59" O.C.
Depth	0" - 30"	T-1 Drive Slip			
Width	15" - 26"	T-13 Standing "S" Slip	59"	26	Transverse Connection 59" O.C.
Depth	0" - 30"	T-1 Drive Slip			
Width	27" - 30"	T-13 Standing "S" Slip	59"	24	Transverse Connection 59" O.C.
Depth	0" - 30"	T-1 Drive Slip			
Width	31" - 36"	T-13 Standing "S" Slip	59"	24	Transverse Connection 59" O.C. 1" x 1" x 18 GA "Z" Maximum 30" from Connection
Depth	0" - 30"	T-1 Drive Slip			
Width	0" - 10"	T-13 Standing "S" Slip	59"	24	Transverse Connection 59" O.C. 1 1/2" x 1" x 18 GA "Z" Maximum 30" from Connection
Depth	0" - 30"	T-1 Drive Slip			

1. All duct to be fabricated from G-90 galvanized steel sheets
2. All duct to be stiffened with machine-formed beads at 12" O.C.
3. All reinforcing to be galvanized steel
4. All reinforcing to be secured to the duct at 8" O.C.
5. All drives over 18" to be reinforced by others
6. Longitudinal seams to be type L-2 button-punch snap-lock

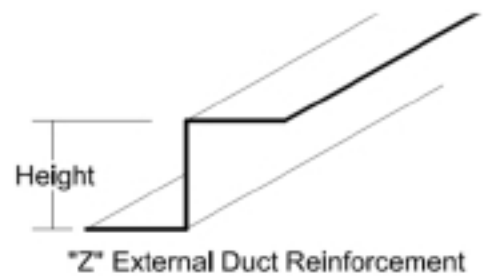
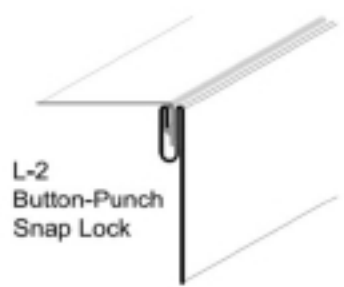

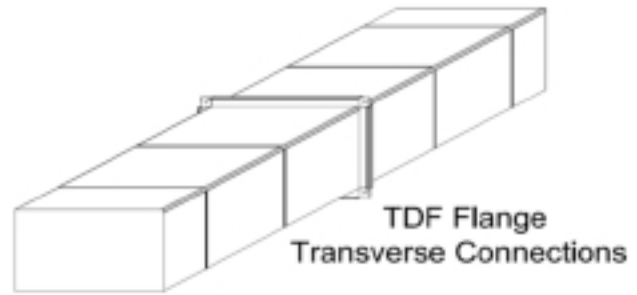

2" WG
Pos. or Neg. **Rectangular Duct Standards**
TDF Transverse Joints

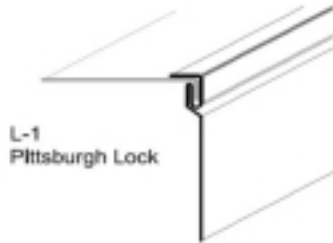

Fabricated in accordance with the 1995 SMACNA HVAC Duct Construction Standards

	Duct Dimension	Joint Connection	Max. Length	Metal Gauge	Reinforcing Size and Longitudinal Spacing
Width	0" - 26"	TDF Flange	56"	26	Transverse Connection 56" O.C.
Depth	0" - 30"				
Width	27" - 30"	TDF Flange	56"	24	Transverse Connection 56" O.C.
Depth	0" - 30"				
Width	31" - 36"	TDF Flange	56"	24	Transverse Connection 56" O.C. 1" x 1" x 18 GA "Z" Maximum 30" from Connection
Depth	0" - 30"				
Width	37" - 54"	TDF Flange	56"	24	Transverse Connection 56" O.C. 1 1/2" x 1" x 18 GA "Z" Maximum 30" from Connection
Depth	0" - 30"				
Width	55" - 60"	* TDF Flange	56"	22	Transverse Connection 56" O.C. 1 1/2" x 1" x 16 GA "Z" Maximum 30" from Connection
Depth	over 30"				
Width	61" - 96"	* TDF Flange	56"	20	Transverse Connection 56" O.C. 2" x 1 1/8" x 12 GA "Z" Maximum 30" from Connection
Depth	over 30"				
Width	97" - 120"	* TDF Flange	56"	18	Transverse Connection 56" O.C. 3" x 1 1/8" x 12 GA "Z" Maximum 30" from Connection
Depth	0" - 30"				

1. All duct to be fabricated from G-90 galvanized steel sheets
2. All duct to be stiffened with machine-formed beads at 12" O.C.
3. All reinforcing to be galvanized steel
4. All reinforcing to be secured to the duct at 8" O.C.
5. Longitudinal seams to be type L-1 Pittsburgh lock
6. All seams to be sealed (Seal Class A)
- * 7. Reinforce all TDF flanges 55" and over with Tie Rod maximum 48" O.C. at each end except where heavier gauge is used in lieu of gauge specified for that size

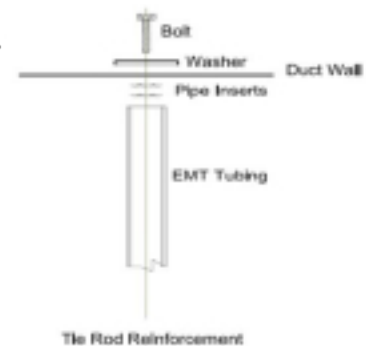



3" WG Rectangular Duct Standards

Pos. or Neg. TDF Transverse Joints

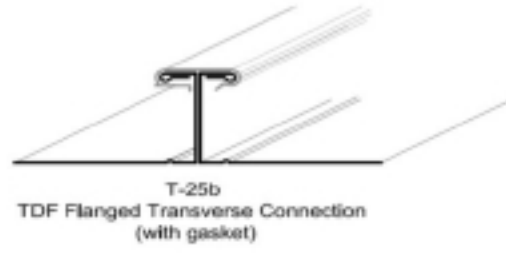
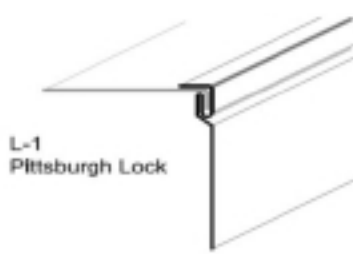

Fabricated in accordance with the 1995 SMACNA HVAC Duct Construction Standards

Duct Dimension	Joint Connection	Max. Length	Metal Gauge	Reinforcing Size and Longitudinal Spacing
0" - 28"	TDF Flange	58"	24	Transverse Connection 58" O.C.
27" - 36"	TDF Flange	58"	24	Transverse Connection 58" O.C. 1 1/2" x 1" x 18 GA "Z" Maximum 48" from Connection
37" - 42"	TDF Flange	58"	22	Transverse Connection 58" O.C. 1 1/2" x 1" x 18 GA "Z" Maximum 36" from Connection
43" - 48"	* TDF Flange	58"	22	Transverse Connection 58" O.C. 1 1/2" x 1" x 16 GA "Z" Maximum 36" from Connection
49" - 54"	* TDF Flange	58"	22	Transverse Connection 58" O.C. 1 1/2" x 1" x 16 GA "Z" Maximum 30" from Connection
55" - 72"	* TDF Flange	58"	20	Transverse Connection 58" O.C. 2" x 1 1/8" x 12 GA "Z" Maximum 36" from Connection
73" - 84"	* TDF Flange	58"	20	Transverse Connection 58" O.C. 2" x 1 1/8" x 12 GA "Z" Maximum 30" from Connection
85" - 98"	* TDF Flange	58"	18	Transverse Connection 58" O.C. 2" x 1 1/8" x 12 GA "Z" Maximum 24" from Connection
97" - 108"	* TDF Flange	58"	18	Transverse Connection 58" O.C. 3" x 1 1/8" x 12 GA "Z" Maximum 24" from Connection
109" - 120"	* TDF Flange	58"	18	Transverse Connection 58" O.C. 3" x 1 1/8" x 10 GA "Z" Maximum 30" from Connection

1. All duct to be fabricated from G-90 galvanized steel sheets
2. All duct to be stiffened with machine-formed beads at 12" O.C.
3. All reinforcing to be galvanized steel
4. All reinforcing to be secured to the duct at 8" O.C.
5. Longitudinal seams to be type L-1 Pittsburgh lock
6. All seams to be sealed (Seal Class A)
- * 7. Reinforce all TDF flanges 43" and over with Tie Rod maximum 48" O.C. at each end except where heavier gauge is used in lieu of gauge specified for that size

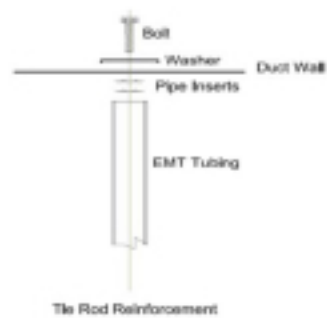



4" WG **Rectangular Duct Standards**
Pos. or Neg. **TDF Transverse Joints**

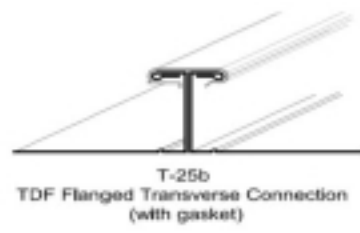
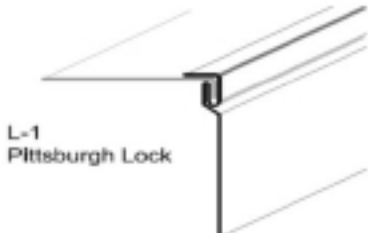

Fabricated in accordance with the 1995 SMACNA HVAC Duct Construction Standards

Duct Dimension	Joint Connection	Max. Length	Metal Gauge	Reinforcing Size and Longitudinal Spacing
0" - 22"	TDF Flange	58"	24	Transverse Connection 58" O.C.
23" - 30"	TDF Flange	58"	24	Transverse Connection 58" O.C. 1 1/2" x 1" x 18 GA "Z" Maximum 36" from Connection
31" - 36"	TDF Flange	58"	22	Transverse Connection 58" O.C. 1 1/2" x 1" x 18 GA "Z" Maximum 36" from Connection
37" - 42"	* TDF Flange	58"	22	Transverse Connection 58" O.C. 1 1/2" x 1" x 16 GA "Z" Maximum 36" from Connection
43" - 60"	* TDF Flange	58"	20	Transverse Connection 58" O.C. 2" x 1 1/8" x 12 GA "Z" Maximum 36" from Connection
61" - 72"	* TDF Flange	58"	20	Transverse Connection 58" O.C. 2" x 1 1/8" x 12 GA "Z" Maximum 30" from Connection
73" - 84"	* TDF Flange	58"	20	Transverse Connection 58" O.C. 2" x 1 1/8" x 10 GA "Z" Maximum 30" from Connection
85" - 96"	* TDF Flange	58"	18	Transverse Connection 58" O.C. 3" x 1 1/8" x 12 GA "Z" Maximum 30" from Connection
97" - 120"	* TDF Flange	58"	18	Transverse Connection 58" O.C. 3" x 1 1/8" x 10 GA "Z" Maximum 30" from Connection

1. All duct to be fabricated from G-90 galvanized steel sheets
2. All duct to be stiffened with machine-formed beads at 12" O.C.
3. All reinforcing to be galvanized steel
4. All reinforcing to be secured to the duct at 8" O.C.
5. Longitudinal seams to be type L-1 Pittsburgh lock
6. All seams to be sealed (Seal Class A)
- * 7. Reinforce all TDF flanges 37" and over with Tie Rod maximum 48" O.C. at each end except where heavier gauge is used in lieu of gauge specified for that size
8. Where reinforcing is required only on two sides, a frame will be provided

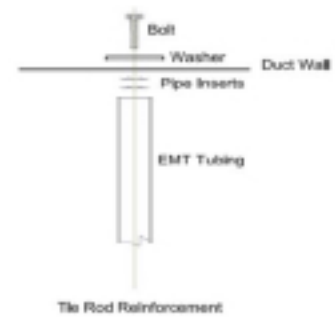

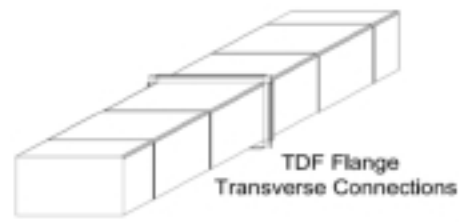

6" WG **Rectangular Duct Standards**
Pos. or Neg. **TDF Transverse Joints**

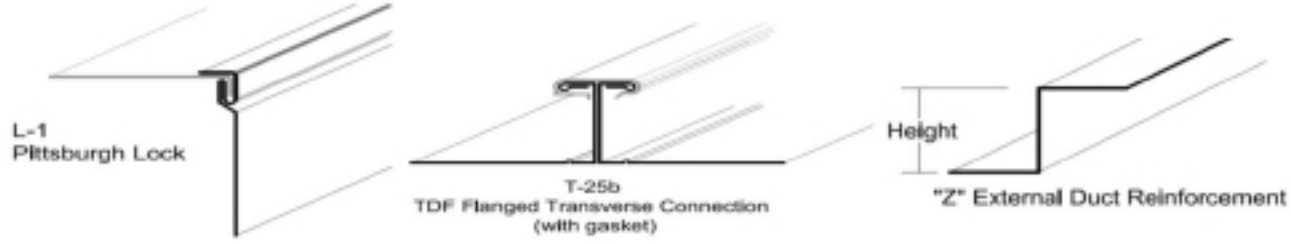

Fabricated in accordance with the 1995 SMACNA HVAC Duct Construction Standards

Duct Dimension	Joint Connection	Max. Length	Metal Gauge	Reinforcing Size and Longitudinal Spacing
0" - 12"	TDF Flange	58"	24	Transverse Connection 58" O.C.
13" - 24"	TDF Flange	58"	22	Transverse Connection 58" O.C.
25" - 30"	TDF Flange	58"	22	Transverse Connection 58" O.C. 1 1/2" x 1" x 18 GA "Z" Maximum 36" from Connection
31" - 36"	* TDF Flange	58"	22	Transverse Connection 58" O.C. 1 1/2" x 1" x 16 GA "Z" Maximum 30" from Connection
37" - 42"	* TDF Flange	58"	22	Transverse Connection 58" O.C. 2" x 1 1/8" x 12 GA "Z" Maximum 30" from Connection
43" - 60"	* TDF Flange	58"	20	Transverse Connection 58" O.C. 2" x 1 1/8" x 12 GA "Z" Maximum 30" from Connection
61" - 72"	* TDF Flange	58"	18	Transverse Connection 58" O.C. 2" x 1 1/8" x 10 GA "Z" Maximum 30" from Connection
73" - 84"	* TDF Flange	58"	18	Transverse Connection 58" O.C. 3" x 1 1/8" x 12 GA "Z" Maximum 24" from Connection
85" - 108"	* TDF Flange	58"	18	Transverse Connection 58" O.C. 3" x 1 1/8" x 10 GA "Z" Maximum 24" from Connection

1. All duct to be fabricated from G-90 galvanized steel sheets
2. All duct to be stiffened with machine-formed beads at 12" O.C.
3. All reinforcing to be galvanized steel
4. All reinforcing to be secured to the duct at 8" O.C.
5. Longitudinal seams to be type L-1 Pittsburgh lock
6. All seams to be sealed (Seal Class A)
- * 7. Reinforce all TDF flanges 31" and over with Tie Rod maximum 48" O.C. at each end except where heavier gauge is used in lieu of gauge specified for that size
8. Where reinforcing is required only on two sides, a frame will be provided

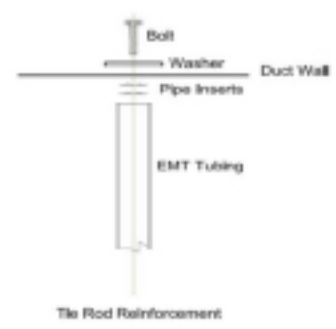



10" WG
Pos. or Neg.

Rectangular Duct Standards

TDF Transverse Joints

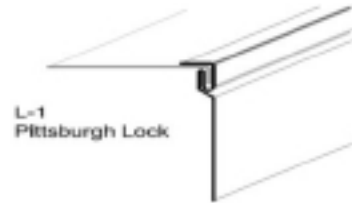

Fabricated in accordance with the 1995 SMACNA HVAC Duct Construction Standards

Duct Dimension	Joint Connection	Max. Length	Metal Gauge	Reinforcing Size and Longitudinal Spacing
0" - 8"	TDF Flange	56"	24	Transverse Connection 56" O.C.
9" - 12"	TDF Flange	56"	24	Transverse Connection 56" O.C. 1" x 1" x 18 GA "Z" Maximum 48" from Connection
13" - 18"	TDF Flange	56"	24	Transverse Connection 56" O.C. 1 1/2" x 1" x 18 GA "Z" Maximum 36" from Connection
19" - 22"	TDF Flange	56"	22	Transverse Connection 56" O.C. 1 1/2" x 1" x 18 GA "Z" Maximum 36" from Connection
23" - 26"	* TDF Flange	56"	22	Transverse Connection 56" O.C. 1 1/2" x 1" x 16 GA "Z" Maximum 36" from Connection
27" - 36"	* TDF Flange	56"	20	Transverse Connection 56" O.C. 2" x 1 1/8" x 12 GA "Z" Maximum 36" from Connection
37" - 42"	* TDF Flange	56"	20	Transverse Connection 56" O.C. 2" x 1 1/8" x 12 GA "Z" Maximum 30" from Connection
43" - 48"	* TDF Flange	56"	18	Transverse Connection 56" O.C. 2" x 1 1/8" x 12 GA "Z" Maximum 30" from Connection
49" - 54"	* TDF Flange	56"	18	Transverse Connection 56" O.C. 2" x 1 1/8" x 10 GA "Z" Maximum 30" from Connection
55" - 60"	* TDF Flange	56"	18	Transverse Connection 56" O.C. 3" x 1 1/8" x 12 GA "Z" Maximum 30" from Connection
61" - 72"	* Ward J Flange	56"	16	Transverse Connection 56" O.C. 3" x 1 1/8" x 10 GA "Z" Maximum 30" from Connection
73" - 120"	* Ward J Flange	56"	16	Transverse Connection 56" O.C. ** 3" x 1 1/8" x 10 GA "Z" Maximum 24" from Connection

- All duct to be fabricated from G-90 galvanized steel sheets
- All duct to be stiffened with machine-formed beads at 12" O.C.
- All reinforcing to be galvanized steel
- All reinforcing to be secured to the duct at 8" O.C.
- Longitudinal seams to be type L-1 Pittsburgh lock
- All seams to be sealed (Seal Class A)
- * Reinforce all TDF flanges 23" and over with Tie Rod maximum 48" O.C. at each end except where heavier gauge is used in lieu of gauge specified for that size
- ** Reinforce Z-bar 73" and over with tie rod at 48" maximum



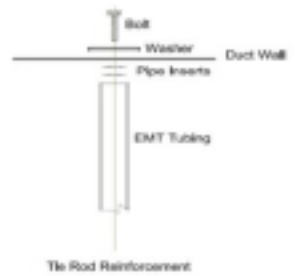

2" WG Rectangular Duct Standards

Pos. or Neg. With Tie Rods



Fabricated in accordance with the 1995 SMACNA HVAC Duct Construction Standards

Duct Dimension	Joint Connection	Max. Length	Metal Gauge	Reinforcing Size and Longitudinal Spacing
0" - 10"	T-6 Hemmed "S" Slip	58"	26	Transverse Connection 58" O.C.
	T-1 Drive Slip			
11" - 26"	TDF Flange	56"	26	Transverse Connection 56" O.C.
27" - 30"	TDF Flange	56"	24	Transverse Connection 56" O.C.
31" - 36"	TDF Flange	56"	22	Transverse Connection 56" O.C.
37" - 42"	TDF Flange	56"	20	Transverse Connection 56" O.C.
43" - 48"	* TDF Flange	56"	20	Transverse Connection 56" O.C.
49" - 60"	* TDF Flange	56"	22	Transverse Connection 56" O.C. (1) Tie Rod maximum 30" from connection
61" - 84"	* TDF Flange	56"	20	Transverse Connection 56" O.C. (1) Tie Rod maximum 30" from connection
85" - 96"	* TDF Flange	56"	20	Transverse Connection 56" O.C. (2) Tie Rod maximum 30" from connection
97" - 120"	* TDF Flange	56"	18	Transverse Connection 56" O.C. (2) Tie Rod maximum 30" from connection

1. All duct to be fabricated from G-90 galvanized steel sheets
2. All duct to be stiffened with machine-formed beads at 12" O.C.
3. All reinforcing to be galvanized steel
4. All internal tie rods to be EMT conduit with threaded inserts
5. Seal transverse joints only (Seal Class C)
- * 6. Reinforce all TDF flanges 55" and over with Tie Rod maximum 43" O.C. at each end except where heavier gauge is used in lieu of gauge specified for that size
7. To be used for all systems not exceeding 2,000 FPM and/or 2" WG

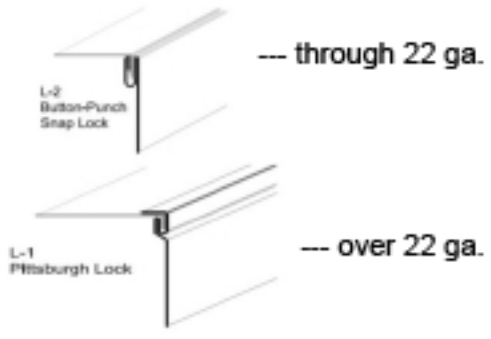

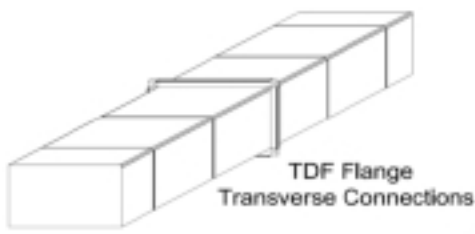

4" WG **Rectangular Duct Standards**
Pos. or Neg. **TDF Transverse Joints and Tie Rods**

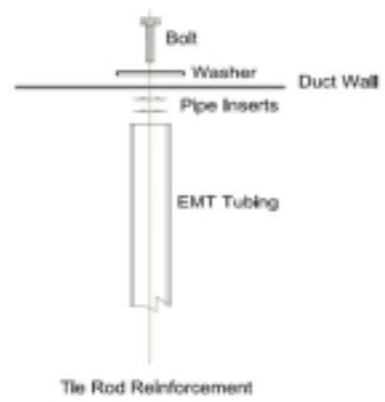
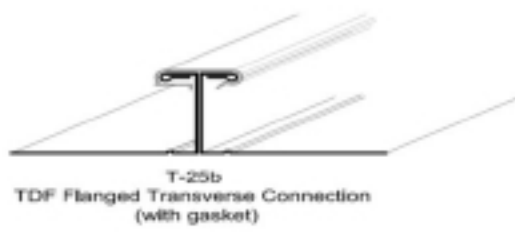
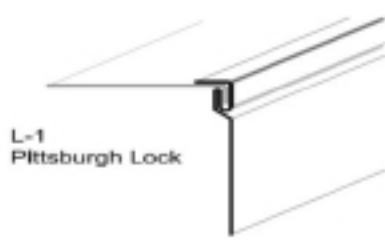

Fabricated in accordance with the 1995 SMACNA HVAC Duct Construction Standards

Duct Dimension	Joint Connection	Max. Length	Metal Gauge	Reinforcing Size and Longitudinal Spacing
0" - 22"	TDF Flange	58"	24	Transverse Connection 58" O.C.
23" - 28"	TDF Flange	58"	22	Transverse Connection 58" O.C.
29" - 30"	* TDF Flange	58"	22	Transverse Connection 58" O.C.
31" - 36"	* TDF Flange	58"	20	Transverse Connection 58" O.C.
37" - 48"	* TDF Flange	58"	22	Transverse Connection 58" O.C. (1) Tie Rod maximum 36" from connection
49" - 60"	* TDF Flange	58"	22	Transverse Connection 58" O.C. (2) Tie Rods maximum 30" from connection
61" - 72"	* TDF Flange	58"	20	Transverse Connection 58" O.C. (2) Tie Rods maximum 30" from connection
73" - 96"	* TDF Flange	58"	18	Transverse Connection 58" O.C. (2) Tie Rods maximum 30" from connection
97" - 120"	* Ward J Flange	60"	16	Transverse Connection 60" O.C. (2) Tie Rods maximum 30" from connection

- All duct to be fabricated from G-90 galvanized steel sheets
- All duct to be stiffened with machine-formed beads at 12" O.C.
- All reinforcing to be galvanized steel
- All internal tie rods to be EMT conduit with threaded inserts
- Longitudinal seams to be type L-1 Pittsburgh lock
- All seams to be sealed (Seal Class A)
- * 7. Reinforce all TDF flanges 29" and over with Tie Rod maximum 48" O.C. at each end

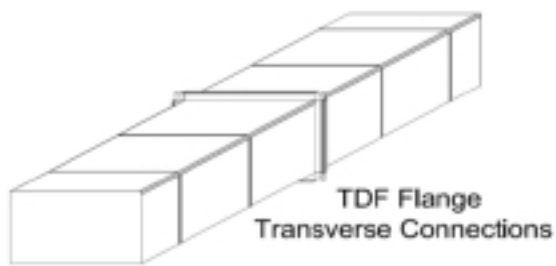

6" WG **Rectangular Duct Standards**
Pos. or Neg. **TDF Transverse Joints and Tie Rods**

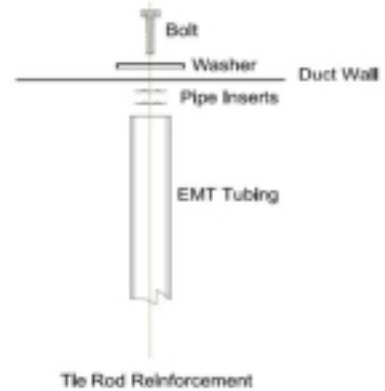
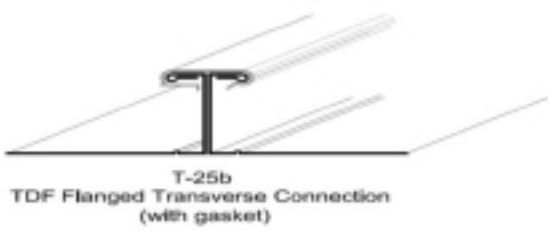
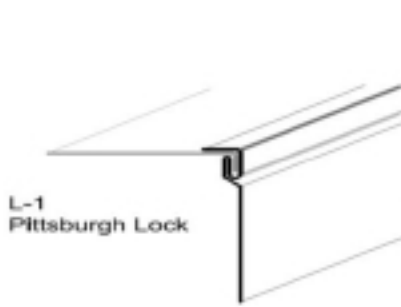

Fabricated in accordance with the 1995 SMACNA HVAC Duct Construction Standards				
Duct Dimension	Joint Connection	Max. Length	Metal Gauge	Reinforcing Size and Longitudinal Spacing
0" - 12"	TDF Flange	58"	24	Transverse Connection 58" O.C.
13" - 24"	TDF Flange	58"	22	Transverse Connection 58" O.C.
25" - 28"	TDF Flange	58"	20	Transverse Connection 58" O.C.
27" - 30"	TDF Flange	58"	18	Transverse Connection 58" O.C.
31" - 36"	* TDF Flange	58"	18	Transverse Connection 58" O.C.
37" - 54"	* TDF Flange	58"	20	Transverse Connection 58" O.C. (1) Tie Rod maximum 30" from connection
55" - 72"	* TDF Flange	58"	18	Transverse Connection 58" O.C. (1) Tie Rod maximum 30" from connection
73" - 96"	* Ward J Flange	60"	16	Transverse Connection 60" O.C. (1) Tie Rod maximum 30" from connection
97" - 120"	* Ward J Flange	60"	16	Transverse Connection 60" O.C. (2) Tie Rods maximum 30" from connection

- All duct to be fabricated from G-90 galvanized steel sheets
- All duct to be stiffened with machine-formed beads at 12" O.C.
- All reinforcing to be galvanized steel
- All internal tie rods to be EMT conduit with threaded inserts
- Longitudinal seams to be type L-1 Pittsburgh lock
- All seams to be sealed (Seal Class A)
- * 7. Reinforce all TDF flanges 31" and over with Tie Rod maximum 48" O.C. at each end